



# COMPREHENSIVE COMPRESSOR OILS GUIDE

PRESENTING OUR FULL RANGE OF QUALITY COMPRESSOR OILS.

KEEPING THE  
WORLD  
RUNNING  
SMOOTHLY.





## 2-MINUTE LUBE SCHOOL

### OVERVIEW

Compressors provide pressurized energy for virtually every industry. We offer a full range of compressor oils that lubricate the moving parts of compressors to improve performance, lower maintenance costs and reduce the formation of harmful deposits.

Compressor oils are specially formulated for the type of compressor, gas to be compressed, discharge temperature and pressure.

#### WHAT DOES A COMPRESSOR LUBRICANT DO?

- Improves performance
- Acts as a sealing fluid
- Serves as a direct contact coolant to absorb the heat of compression
- Provides a protective surface film to minimize friction and protect exposed metal parts
- Lowers maintenance costs
- Reduces the formation of harmful deposits

#### Rotary Screw Compressor Main Friction Points

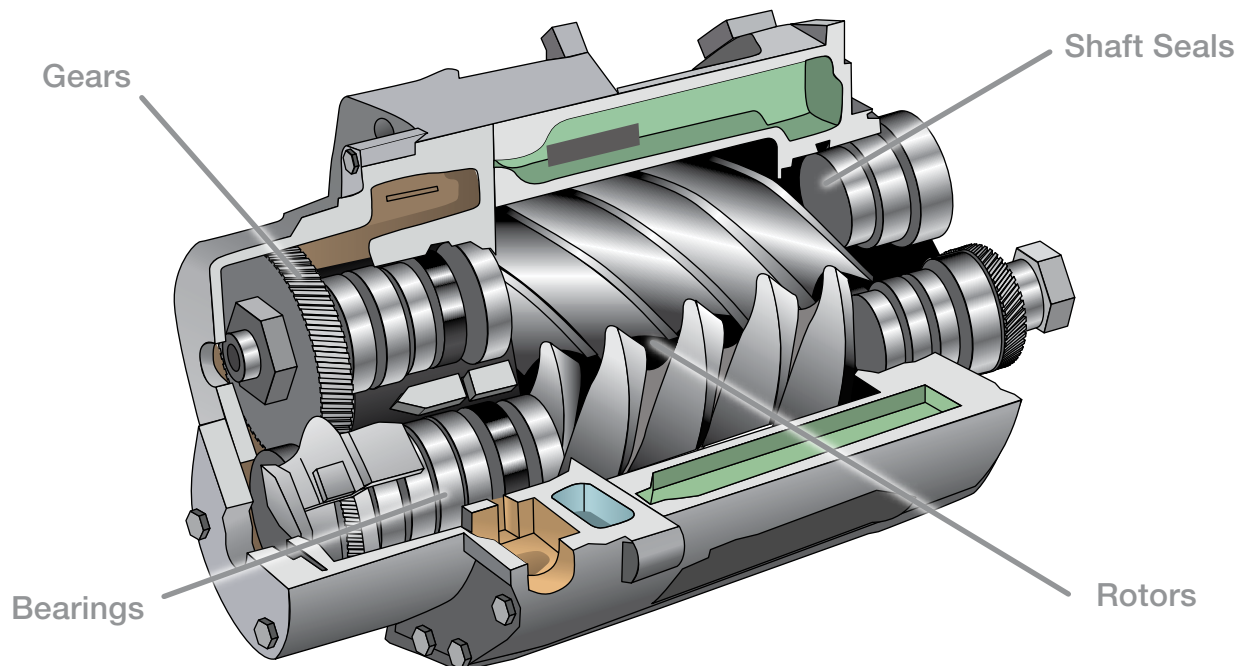

Conventional compressor oil is typically changed every 4,000 hours; a synthetic oil, every 8,000 hours. In terms of wear, a compressor operating for 8,000 hours is roughly equivalent to putting 480,000 miles on your car.

# COMPRESSOR BASICS

There are many types of compressors, including rotary screw, rotary vane, reciprocating and centrifugal compressors. Rotary screw compressors represent approximately 80 percent of the industrial market for compressors.

All compressors generally work in the same manner as a rotary screw compressor (see diagram below) to increase gas pressure by reducing its volume, thereby delivering pressure energy.

## BASIC COMPRESSOR SYSTEM DIAGRAM

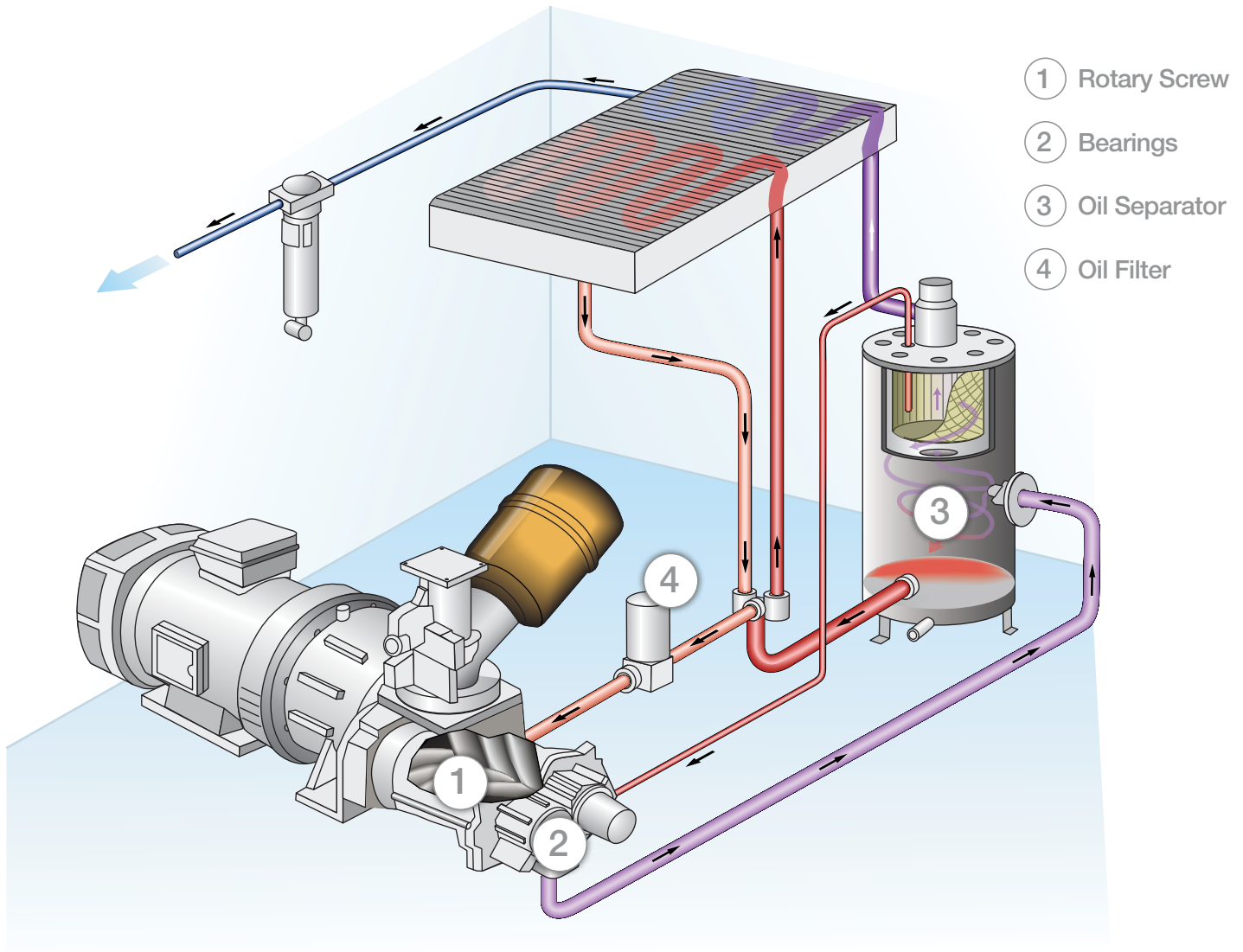

# SYNTHETIC OIL BENEFITS

## IN ROTARY SCREW AIR COMPRESSORS:

- Extended oil service life (8,000+ hours)
- Reduced formation of sludge, varnish and carbonaceous deposits
- Electrical savings of 2–5%
- Cooler oil temperature
- Cooler discharge of compressed air
- Lower oil consumption
- Less oil carryover

## IN CENTRIFUGAL COMPRESSORS:

- Increased energy efficiency
- Extended bearing life
- Lubricant does not contact the compressed air

## IN RECIPROCATING AIR COMPRESSORS:

- Reduced carbon deposits on compressor valves
- Reduced oil feed rates (20–30% lower, in drops per minute) to compressor cylinders
- Higher flash points and fire points versus mineral oils
- Higher auto-ignition temperatures versus mineral oils
- Reduced wear of piston rings and packing

## IN ROTARY VANE AIR COMPRESSORS:

- Reduced wear and formation of gums and sludge on vanes and slots
- Increases in oil drain intervals where the lubricating system is a circulatory system
- Reduced oil feed rates in dpm (drops per minute) in total loss (non-circulatory) systems

## SYNDUSTRIAL® PAG COMPRESSOR OIL

Premium-quality synthetic lubricant for use in centrifugal and oil-flooded rotary screw and rotary vane compressors processing natural gas, carbon dioxide, propane or other hydrocarbon gases

Specially formulated to resist hydrocarbon dilution and oil absorption, Syndustrial PAG Compressor Oil is available in three viscosity grades: ISO 46, 68, and 100. It is formulated with synthetic polyalkylene glycol (PAG) base oils and carefully selected additives to provide long service life, excellent wear protection, resistance to washout and lubricant carryover, and protection against rust and corrosion. Its outstanding oxidation resistance and thermal stability at high temperatures, high viscosity index, and excellent low-temperature properties make it suitable for year-round use over a wide temperature range.



## APPLICATIONS:

- Oil-flooded rotary screw and rotary vane compressors processing natural gas, carbon dioxide or other hydrocarbon gases
- Centrifugal compressors processing propane refrigerant, including York centrifugal compressors where York Oil Q (ISO VG 46) or York Oil R (ISO VG 68) is recommended

Note: Not compatible with petroleum compressor oils. Care should be taken to avoid mixing the two products. When switching over from mineral oil to Syndustrial PAG Compressor Oil, a complete flush, drain and refill should be performed.

## FEATURES/BENEFITS:

- Highly resistant to dilution by hydrocarbon gases
- Resists washout by condensed hydrocarbon liquids
- Resists absorption into the gas stream and subsequent carryover of the lubricant downstream
- Outstanding oxidation resistance and thermal stability at high temperatures
- High viscosity index and low pour point for use over a wide temperature range
- High film strength for wear protection
- Extended service intervals compared to conventional mineral oil-based lubricants
- Compatible with commonly used seals, gaskets and hoses\*

\*Syndustrial PAG Compressor Oil is compatible with neoprene, silicone rubber, torlon, vespal and viton, as well as epoxy paints. It is not compatible with oil-based paints or solvents, such as diesel fuel, kerosene, heptane, methanol, ethylene glycol or triethanolamine.

## SYNCON® R&O OIL

Multipurpose synthetic circulating oil particularly recommended for circulating systems and lightly loaded enclosed industrial gearboxes where operating conditions may be unfavorable or too severe for conventional mineral oil-based circulating oils.

Syncon R&O Oil is designed for use in a wide variety of industrial applications. It is available in nine viscosity grades: ISO 32, 46, 68, 100, 150, 220, 320, 460 and 680. The lighter viscosity grades (ISO 32, 46, 68 and 100) are recommended for use in rotary air compressors, circulating pumps, vacuum pumps and electric motor bearings operating under severe-service conditions or at extreme temperatures. The heavier viscosity grades (ISO 150, 220, 320, 460 and 680) are recommended for use in lightly loaded gearboxes that do not require an extreme-pressure gear oil. Syncon R&O Oil is formulated with synthetic polyalphaolefin (PAO) base fluids and select additives to provide excellent protection against rust, corrosion and deposit formation.



### APPLICATIONS:

- Rotary air compressors where the manufacturer specifies a PAO-based lubricant
- Plain and rolling element bearings operating at very high or very low temperatures
- Lightly to moderately loaded enclosed industrial gearboxes that do not require an extreme-pressure gear lubricant
- Industrial worm gear drives with bronze-on-steel gears
- Circulating systems of paper machine dryer sections and calendar stacks
- Lubrication of upper cylinders of natural gas and process gas compressors
- Industrial equipment operating over a wide temperature range where inhibited mineral oil is recommended

Note: For information on compatibility with seals, paints and plastics, please call our Technical Support Hot Line at 1.877.445.9198.

### FEATURES/BENEFITS:

- Outstanding resistance to thermal breakdown at high temperatures
- Outstanding oxidation resistance to minimize sludge and varnish formation
- Protects against wear, rust and corrosion
- Good water-separating properties and foam resistance
- Excellent low-temperature fluidity
- Low carbon-forming tendencies for use in rotary air compressors
- Extended service intervals compared to conventional mineral oil-based lubricants
- Compatible with mineral oil-based lubricants\*

\*For optimum performance, the mineral oil lubricant should be drained before using Syncon R&O Oil. Mixing the two products can reduce the effectiveness and performance advantages normally gained by using Syncon R&O Oil.

## SYNCON REFRIGERATION OIL

Premium-quality synthetic lubricant for use in rotary screw compressors in refrigeration service compressing ammonia, methyl chloride or carbon dioxide

Available in one viscosity grade, ISO 68, Syncon Refrigeration Oil is formulated with synthetic polyalphaolefin base oils and a carefully balanced additive package to provide long service life, excellent deposit control, protection against rust and corrosion, and resistance to foaming. It has outstanding oxidation resistance and thermal stability at high temperatures to help minimize deposit formation and provide extended service intervals. It has a very low pour point and outstanding thermal stability for use in ammonia refrigeration systems.

### APPLICATIONS:

- Rotary screw refrigeration compressors operating under severe-service conditions
- Rotary compressors used in ammonia and carbon dioxide refrigeration systems
- Ammonia and carbon dioxide manufacturing plants
- Cold storage warehouses and distribution facilities
- Chemical plants
- Ice plants

Note: Not recommended for use with chlorinated hydrocarbons (CFCs) such as Freon R12, R22 or R502, or with fluorinated hydrocarbons, such as HFC-134A.

### FEATURES/BENEFITS:

- Outstanding low-temperature fluidity
- Outstanding oxidation resistance and thermal stability at high temperatures
- Excellent deposit control
- Low volatility for lower oil consumption and less makeup oil
- Extended service intervals compared to conventional mineral oil-based refrigeration oils

# SYNTHETIC

## SYNDUSTRIAL® R&O OIL

Premium-quality synthetic diester lubricant developed primarily for use in reciprocating and some rotary air compressors operating under severe-service conditions, and in moisture-free environments

Syndustrial R&O Oil is available in four viscosity grades: ISO 32, 68, 100 and 150. It is particularly recommended for use in applications where operating conditions may be unfavorable or too severe for conventional mineral oil-based lubricants. It is formulated with synthetic diester base fluids and select additives to provide long service life, good wear protection, and protection against rust and corrosion. It has excellent low-temperature properties for use over a wide temperature range and good natural detergency.



### APPLICATIONS:

- Reciprocating air compressors and some rotary air compressors operating in a dry environment\*
- Circulating systems requiring a synthetic diester lubricant
- Elliott steam turbines where the manufacturer specifies a synthetic diester lubricant
- Plain and rolling element bearings operating at very high or very low temperatures
- Industrial equipment operating over a wide temperature range where an inhibited mineral oil is recommended\*\*

\*Always follow the equipment manufacturer's recommendations for selecting the proper viscosity grade and for preferences regarding the use of diester lubricants. Typically, the ISO 32 and ISO 68 grades are recommended for rotary air compressors; the ISO 100 grade is recommended for reciprocating air compressors.

\*\*Syndustrial R&O Oil is not compatible with mineral oil-based lubricants. Mixing should be avoided to ensure optimum performance.

### FEATURES/BENEFITS:

- Excellent resistance to thermal breakdown at high temperatures
- Excellent oxidation resistance to help minimize sludge and varnish formation
- Protects against wear, rust and corrosion
- Natural detergency
- Excellent low-temperature properties
- Extended service intervals compared with conventional mineral oil-based lubricants

Note: For information on compatibility with seals, paints and plastics, please call our Technical Support Hot Line at 1.877.445.9198.

## SYNDUSTRIAL ROTARY COMPRESSOR OIL

Premium-quality synthetic lubricant for use in oil-flooded rotary screw, rotary lobe and rotary vane air compressors where operating conditions are unfavorable or too severe for conventional mineral oil-based compressor oils

Syndustrial Rotary Compressor Oil is formulated with a blend of synthetic polyalkylene glycol and synthetic ester base oils and carefully selected additives. It has outstanding oxidation resistance and thermal stability at high temperatures to minimize deposit formation and provide long service life. It is formulated to outperform conventional paraffinic or naphthenic compressor oils in oxidation resistance and deposit control; has better thermal stability at high temperatures to minimize sludge and varnish formation; and has lower volatility. Expect longer service intervals and less maintenance than with conventional petroleum oils.

### APPLICATIONS:

- Oil-flooded rotary screw, rotary lobe and rotary vane air compressors where the manufacturer specifies a synthetic polyglycol/ester lubricant
- Drop-in replacement for OEM-branded polyglycol-based compressor oils

Note: Not compatible with petroleum compressor oils. Care should be taken to avoid mixing the two products. When switching over from mineral oil to Syndustrial Rotary Compressor Oil, a complete flush, drain and refill should be performed.

### FEATURES/BENEFITS:

- Outstanding oxidation resistance and thermal stability at high temperatures
- High viscosity index and very low pour point for use over a wide temperature range
- Excellent cooling and heat transfer properties
- Excellent deposit control
- High film strength for wear protection
- Low volatility for lower oil consumption and less makeup oil
- Extended service intervals compared with conventional mineral oil-based lubricants
- Compatible with commonly used seals, gaskets and hoses\*

\*Syndustrial Rotary Compressor Oil is compatible with neoprene, silicone rubber, torlon, vespal and viton, as well as epoxy paints. It is not compatible with oil-based paints or with solvents, such as diesel fuel, kerosene, heptane, methanol, ethylene glycol or triethanolamine.



# **PHILLIPS 66 LUBRICANTS POWERFUL COMPRESSOR PROTECTION**

# SYNTHETIC BLEND

## PREMIUM GAS COMPRESSOR OIL

Premium-quality synthetic blend lubricant for use as a crankcase oil and for cylinder lubrication in reciprocating compressors in natural gas service. Formulated to minimize the effects of gas dilution and oil absorption

Premium Gas Compressor Oil is available in two viscosity grades: ISO 68 and 150. It is formulated with a carefully balanced blend of synthetic ester and hydrotreated paraffinic base oils and select additives to provide excellent service and protection over a wide temperature range. It has excellent oxidation resistance and thermal stability at high temperatures, and has a high viscosity index and good low-temperature properties for year-round use. It protects against rust and corrosion, and contains a special inhibitor to resist corrosion caused by hydrogen sulfide in sour gas.

### APPLICATIONS:

- Industrial reciprocating compressors pumping natural gas
- Reciprocating compressors commonly found in remote gas gathering stations
- Oil flooded rotary screw and rotary vane gas compressors

### FEATURES/BENEFITS:

- Excellent oxidation resistance and thermal stability at high temperatures
- High viscosity index and low pour point for use over a wide temperature range
- Formulated to minimize the effects of gas dilution and oil absorption
- Low varnish-forming tendency
- Resists hydrogen sulfide corrosion
- Protects against rust and corrosion

## PREMIUM ROTARY AIR COMPRESSOR OIL

Premium-quality semi-synthetic lubricant for use in rotary air compressors operating under moderate to severe service conditions. Formulated to provide enhanced thermal and oxidative stability at high temperatures

Premium Rotary Air Compressor Oil is available in one viscosity grade: ISO 46. It is formulated with a blend of synthetic and premium hydrocracked paraffinic base oils and select additives. It has excellent oxidation resistance and thermal stability at high temperatures, plus natural detergency to minimize deposit formation and provide long service life. It has low volatility to help reduce oil consumption, good low-temperature properties, and protects against rust and corrosion. It also has good water-separating properties and is resistant to foam buildup.

### APPLICATIONS:

- Oil-flooded rotary screw, rotary lobe and rotary vane air compressors
- Circulating systems requiring a semi-synthetic lubricant
- Industrial equipment operating over a wide temperature range where an inhibited mineral oil is recommended
- Industrial equipment where operating conditions are too severe for conventional mineral oil-based R&O-inhibited circulating oils
- Not recommended for use in reciprocating compressors or gas compression service

### MEETS THE PERFORMANCE REQUIREMENTS OF:

- DIN 51506, Air Compressor Lubricant Standard, Grade VDL
- DIN 51517 Part 2, Lubricating Oils, Type CL
- DIN 51517 Part 3, Lubricating Oils, Type CLP

### FEATURES/BENEFITS:

- Semi-synthetic formulation
- Excellent resistance to thermal breakdown at high temperatures
- Excellent oxidation resistance to minimize sludge and varnish formation
- Good protection against wear, rust and corrosion
- Natural detergency
- Good low-temperature properties
- Good water-separating properties and foam resistance
- Low carbon-forming tendency





# CONVENTIONAL

## AIR COMPRESSOR OIL

High-quality, non-detergent circulating oil developed primarily for use in older reciprocating air compressors. It also is recommended for use in other industrial applications where the equipment manufacturer specifies a non-detergent, ISO VG 100 / SAE 30 mineral oil.

Air Compressor Oil is formulated to provide excellent oxidation resistance, rust and corrosion protection, and resistance to foaming. It has excellent oxidation resistance and thermal stability at high temperatures to minimize deposit formation and provide long service life. It protects against rust and corrosion. It has good water-separating properties to minimize the formation of emulsions and is resistant to excessive foam buildup.

### APPLICATIONS:

- Older reciprocating air compressors with low discharge temperatures
- Deep well water pump gear drives
- Vacuum pumps
- Lightly loaded enclosed industrial gear drives where an AGMA 3 (non-EP) oil is specified
- Industrial applications that require a non-detergent, ISO VG 100 / SAE 30 oil

### FEATURES/BENEFITS:

- Excellent oxidation resistance and thermal stability
- Protects against sludge and varnish formation
- Protects against rust and corrosion
- Good water-separating properties
- Good foam resistance
- Low carbon-forming tendency

## GAS COMPRESSOR OIL

High-quality lubricant developed for the lubrication of oil-flooded rotary compressors and reciprocating compressors in natural gas service. Formulated to minimize the effects of gas dilution and oil absorption

Gas Compressor Oil is available in three viscosity grades: ISO 100, 150, and 200. It is particularly recommended for applications where the compressor outlet pressure is less than 150 PSIG, the specific gravity of the gas stream is less than 1.0, and the gas outlet temperature is well above the condensation point of the gas. It is formulated with high-quality, hydrocracked paraffinic base oils and select additives to provide excellent service and protection in gas compression service. It features excellent oxidation resistance and thermal stability at high temperatures.

### APPLICATIONS:

- Oil-flooded rotary screw, rotary lobe and rotary vane compressors in natural gas service
- Industrial reciprocating compressors pumping natural gas
- Reciprocating compressors commonly found in remote gas gathering stations

### FEATURES/BENEFITS:

- Excellent oxidation resistance and thermal stability at high temperatures
- Minimizes the effects of gas dilution and oil absorption
- Good wear protection and foam resistance
- Protects against rust and corrosion

## WET GAS COMPRESSOR OIL

High-quality lubricant developed for oil-flooded rotary compressors and for cylinder lubrication in reciprocating compressors in natural gas service

Wet Gas Compressor Oil is available in one viscosity grade: ISO 220. It is specially formulated to minimize the effects of gas dilution and oil absorption, and to resist wash-off in compressors handling "wet" gas. It is particularly recommended for use in applications where the gas outlet temperature is well above the condensation point of the gas. It is formulated with high-quality paraffinic base oils and select additives to provide excellent service and protection in gas compression service. It features excellent oxidation resistance and thermal stability at high temperatures.

### APPLICATIONS:

- Oil-flooded rotary screw, rotary lobe and rotary vane compressors handling wet natural gas
- Industrial reciprocating compressors pumping wet natural gas
- Reciprocating compressors commonly found in remote gas gathering stations

### FEATURES/BENEFITS:

- Excellent oxidation resistance and thermal stability
- Resists lubricant "wash-off"
- Minimizes the effects of gas dilution and oil absorption
- Protects against wear, rust and corrosion
- Good foam resistance

# CONVENTIONAL

## AMMONIA COMPRESSOR OIL

High-quality circulating oil developed for use in reciprocating, centrifugal and rotary screw compressors used in ammonia refrigeration systems, as well as refrigeration systems using carbon dioxide.

Ammonia Compressor Oil is available in three viscosity grades: ISO 32, 46, and 68. It is formulated to resist degradation when exposed to nitrogen compounds and acids formed when compressed ammonia comes into contact with the oil and condensed water. It has excellent oxidation resistance and thermal stability at high temperatures to minimize sludge and varnish formation, and provide long service life. It has a low pour point for use in ammonia refrigeration systems used for sub-zero cooling.

### APPLICATIONS:

- Compressors in refrigeration systems using ammonia or carbon dioxide
- Ammonia and carbon dioxide manufacturing plants
- Cold storage warehouses and distribution facilities
- Chemical plants
- Ice plants
- Not recommended for use with CFC, HCFC, or HFC refrigerants such as Freon®-12, Freon®-22 or R-134a

Meets the performance requirements of leading ammonia refrigeration compressor manufacturers, including Copeland, Frick, Sullair, Vilter and York. The ISO 68 viscosity grade is recommended for use where the OEM specifies:

- Frick Oil No. 3
- Vilter OEM Refrigeration Oil
- York Oil "C"

### FEATURES/BENEFITS:

- Excellent oxidation resistance
- Provides longer service life than conventional naphthenic ammonia refrigeration oils
- Low pour point
- Good foam resistance
- Excellent resistance to chemical degradation

## REFRIGERANT COMPRESSOR OIL

Highly refined, naphthenic mineral oil developed primarily for use in reciprocating and rotary screw compressors in refrigeration systems using ammonia, carbon dioxide or non-HFC refrigerants

Refrigerant Compressor Oil is manufactured from carefully selected wax-free base stocks to have a low pour point and a low floc point. It meets the performance requirements of leading OEMs for use in refrigeration system compressors where the manufacturer specifies a naphthenic mineral oil. It has excellent low-temperature properties, good oxidation stability and low carbon-forming tendency. It provides good lubricity and excellent miscibility with non-HFC refrigerants. Its solvency properties and light color make it an ideal process oil and blending component..

### APPLICATIONS:

- Compressors in refrigeration systems using ammonia, carbon dioxide, CFC or HCFC refrigerants, such as R-11, R-12, R-22 and R-502\*
- Plain and rolling-element bearings operating at low temperatures and under light loads
- Drive chains
- Process oil
- Can also be used as a general-purpose, light-duty lubricant for industrial machinery operating in cold environments

\* Not recommended for use with HFC refrigerants such as HFC-134a.

### FEATURES/BENEFITS:

- Excellent low-temperature properties
- Wax free
- Good oxidation stability
- Low carbon-forming tendency
- Excellent miscibility with non-HFC refrigerants
- Good lubricity and solvency

# COMPRESSOR OIL OEM CROSS-REFERENCE CHART

Use this chart to identify the correct compressor oil for your needs.

OEM	OEM PRODUCT	PHILLIPS 66 LUBRICANTS EQUIVALENT
Atlas Copco	GA-8K*	Syncon® R&O 46
	HD Roto Fluid Plus*	Syncon R&O OIL 46**
	Par Oil M	Turbine Oil 46
	Par Oil S	Syncon R&O 46**
	Roto-Inject Fluid	Turbine Oil 46**
	Roto-Xtend Duty Fluid	Syncon R&O 46**
Compair	CS 100	Syndustrial® R&O Oil 32
	CS 200	Syndustrial R&O Oil 68
	CS 300	Syndustrial R&O Oil 100
	CS 400	Syndustrial R&O Oil 150
	CS 5000XL	Syndustrial R&O Oil 68
	CS 600	Syncon R&O 46
	CSS 20 (Food Grade)	Syncon FG Hydraulic Fluid 46
Gardner Denver	Aeon 2000 (GD 800)	Syncon R&O 32**
	Aeon 4000	Premium Rotary Compressor Oil
	Aeon 500 (GD 500)	Multipurpose R&O 100**
	Aeon 9000 SP	Syncon R&O Oil 46
	Aeon AC FG	Syncon FG Hydraulic 100
	Aeon AC SY	Syndustrial R&O Oil 100
	Aeon CL	Syncon R&O 46**
	Aeon PD (Sutorbilt)	Syncon R&O 220
Ingersoll Rand	SSR Coolant	Syndustrial R&O Oil 68
	T-30 Select All Season	Syndustrial R&O 100
	Techtrol Gold III	Syndustrial Rotary Compressor Oil 32/46
	XHP 1001	Syncon R&O 150**
	XHP 505	Syncon R&O 68
	XHP 605	Syncon R&O 68
	XL 700	Syndustrial R&O Oil 100
	XL 740 HT	Syndustrial R&O Oil 150
	XL-T30	Syncon R&O 100

OEM	OEM PRODUCT	PHILLIPS 66 LUBRICANTS EQUIVALENT
Kaeser	Omega SB 220	Syncon R&O 220
	Omega SB 320	Syncon R&O 320
	Sigma 8000 S-100	Syndustrial R&O 100
	Sigma 8000 S-150	Syndustrial R&O 150
	Sigma 8000 S-320	Syncon R&O 32
	Sigma 8000 S-460	Syncon R&O 46
	Sigma 8000 S-680	Syncon R&O 68
	Leroi	SSL-46+
Palatek	PalaSyn 45	Syncon R&O Oil 46
	Pallube 32	Syndustrial Rotary Compressor Oil 32/46
Quincy	Quin-Syn PG	Syndustrial Rotary Compressor Oil 32/46
	Quin-Syn Plus	Syncon R&O Oil 46**
Sullair	AWF	Powerflow™ HE 32**
	Food Grade	Syncon FG Hydraulic Fluid 100
	LLL-4-100	Syncon R&O 100
	LLL-4-32	Syncon R&O 32
	LLL-4-46	Syncon R&O 46
	Sullube 32	Syndustrial Rotary Compressor Oil 32/46

\* Discontinued

\*\* Consider Using (Please consult the Technical Hotline prior to making this conversion)

# INDUSTRIAL SOLUTIONS



WIRELINE



FOOD GRADE

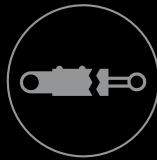

HYDRAULICS



TURBINE



METAL WORKING

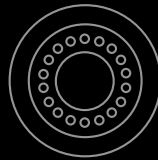

BEARINGS



COMPRESSORS



GEARS



LUBRICANTS

For more information, call our Technical Hotline at **877.445.9198** | **PHILLIPS66LUBRICANTS.COM**